

ADJUSTABLE STEP-MATE STANDS - ASP-36-3-SS

APPROX WEIGHT: 85.60 lbs.
DOES NOT INCLUDE WEIGHT OF POWER OR PACKAGING!!!

*** ANY ADDITIONS, DELETIONS, OR OMISSIONS MUST BE CORRECTED ON THIS DRAWING AS THIS DRAWING WILL BE CONSIDERED ALL INCLUSIVE ***

ALL GRAPHICS PROVIDED ARE FOR REFERENCE ONLY. IF CERTAIN DIMENSIONS ARE CRITICAL PLEASE VERIFY THOSE DIMENSIONS WITH YOUR SALESPERSON

ALL GRAPHICS PROVIDED ARE FOR REFERENCE ONLY. IF CERTAIN DIMENSIONS ARE CRITICAL PLEASE VERIFY THOSE DIMENSIONS WITH YOUR SALESPERSON

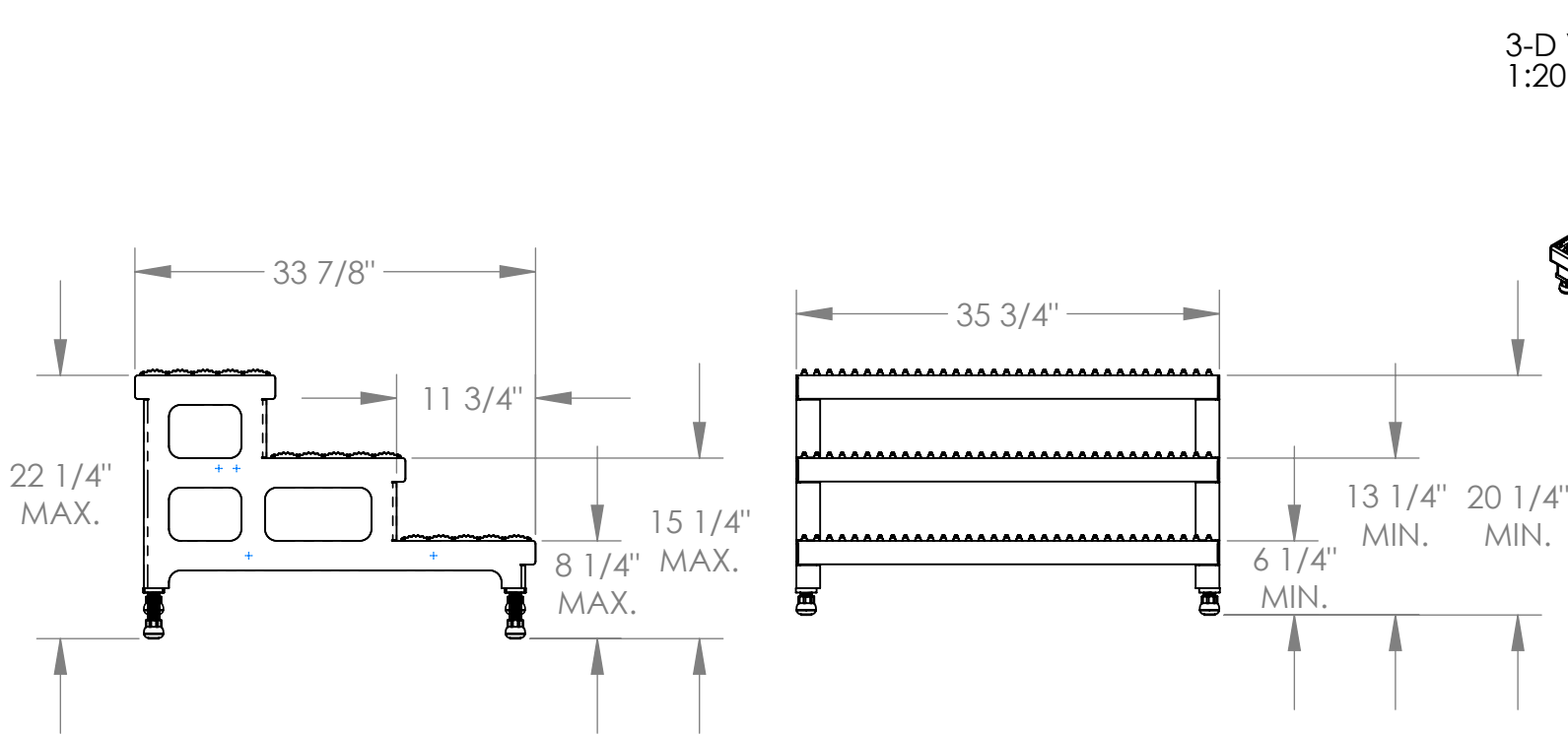

3-D VIEW
1:20 SCALE

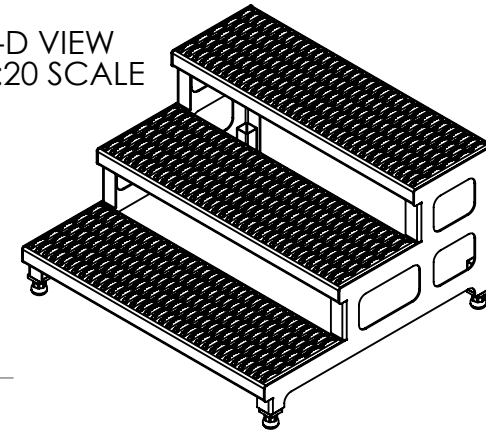

STANDARD FEATURES

MODEL NUMBER IS ASP-36-3-SS

CAPACITY: 500 LBS

OVERALL WIDTH: 35 3/4"

OVERALL LENGTH: 33 7/8"

BOTTOM STEP HEIGHT: MIN. 6 1/4", MAX. 8 1/4"

MIDDLE STEP HEIGHT: MIN. 13 1/4", MAX. 15 1/4"

TOP STEP HEIGHT: MIN. 20 1/4", MAX. 22 1/4"

STEPS:

-SERRATED STAINLESS STEEL 11 3/4" DEEP

LEGS:

-ADJUSTABLE

-ANTI-SLIP TIPS

SPECIAL FEATURES

NONE

DIMENSION TOLERANCE ± 1/4"

| | | |
|--|--|--|
| APPROVAL | I, THE UNDERSIGNED, AGREE THAT THE PRODUCT AS REPRESENTED SATISFIES DESIGN AND DIMENSION REQUIREMENTS. I ALSO ACKNOWLEDGE MY DUTY TO CONFIRM PRODUCT AND INSTALLATION COMPLIANCE WITH ALL APPLICABLE FEDERAL, STATE AND LOCAL REGULATIONS AND STANDARDS. | |
| | ANY MODIFIED UNITS ARE NON-RETURNABLE | |
| | [] As drawn [] As marked | |
| | Signed: _____ Date: _____ | |
| Printed Name: _____ | | |
| LEAD TIME WILL START UPON RECEIPT OF SIGNED APPROVAL DRAWING | | |

| | |
|---|--|
| FOR INTERNAL USE ONLY PROJECT SIGN OFF | |
| SALES | |
| ENG. | |
| FAB. | |
| POWER | |

| | | |
|----------------------|-------------|------------|
| DISTRIBUTOR'S NAME: | | P.O.# |
| VESTIL MANUFACTURING | | X |
| DRAWN BY: SJA | | W.O.# |
| DATE: 12/12/14 | | X |
| REFERENCE: X | SCALE: 1:16 | SALES: X |
| QUOTED LEAD TIME: X | QUOTE # | FILE NAME: |
| | X | 14-007-298 |